



Introduction

The Nixon range of turbine flowmeters offers high accuracy and high reliability. Over 30 years, thousands of units have been sold to all classes of industry, and the meters have an excellent reputation for durability.

Many leading flowmeter companies in the U.K. and abroad have the confidence to put their name on our range of turbine flowmeters, a sign of the high regard in which the product is held.

The range has been modified and extended over the last few years to provide a reasonably priced general purpose flow transmitter. We now produce the units entirely in-house to control quality and availability. The range is available on short deliveries, and popular sizes are held ex-stock.

Available in a wide variety of body sizes and styles, all NT flowmeters possess an electrical pulse output directly proportional to flowrate, based upon the operating principle described in this publication. Remote flowrate indication, alarms, totalising and batch control functions are available utilising our wide range of secondary electronic instruments.

The flowmeters are suitable for use on lubricating or non-lubricating liquids of low to medium viscosity and are largely insensitive to density variations, pressure or temperature fluctuations.

Contact parts are produced from 316 stainless steel, except rotors which must possess good magnetic qualities, and here 431 stainless is used or Ferralium

alloy depending upon the corrosive properties of the liquid.

Standard end connections are screwed BSP parallel thread with included 30 degree internal cones to BS5200, but Ermeto threads are also available. Flanged meters are normally to ANSI 150 or BS4504 (DIN) standards, but older type flanges to BS10 tables D-H may also be fitted.

A unique feature of the design is the use of helically milled rotors cut from solid in sizes up to 65mm. Bearing bushes are of PTFE/Carbon HY49 or similar, or tungsten carbide depending upon the nature of the metered fluid. In all cases, the spindle is of tungsten carbide with Cobalt binder, and thrust balls of tungsten carbide. Stainless steel ball races are used in the smaller sizes.

The electrical signal is a sinusoidal pulse of minimum height 50mV peak at lowest flowrate, rising to 800mV peak at max flowrate. For normal transmission distances pre-amplifiers are not essential since pulse shaping and conditioning are carried out in the appropriate electronic readout unit. In cases where heavy electrical noise is present or where transmission distances are over 500 metres, pre-amplifiers of standard or intrinsically safe design are available as head mounted weatherproof units and loop powered.

Performance and other details are listed on Technical Data tables on pages 2 & 3.





Technical Data

- **Linear Accuracy** $\pm 0.5\%$ over 10:1 range
- **Repeatability** $\pm 0.1\%$ of reading
- **Response Time** 50 milliseconds for 50% step change in flowrate
- **Output Signal** Sinusoidal pulses
50mV - 800mV peak
varying with flowrate
- **Operating Pressure** Twice the pressure drop across the meter plus vapour pressure of liquid
- **Pressure Drop** 0.2 - 0.5 bar depending on meter size
- **Flow Range** 10:1 as standard
- **Temperature** Wider ranges possible
-30°C min
150°C max (standard coil)
400°C special design
120°C intrinsically safe
- **Transmission Distance** 500 metres max without pre-amplifiers for low noise environment
- **Mounting Altitude** Horizontal or vertical (flow upwards) or inclined
- **Maximum Pressure** Limited only by end fittings

Parts and Material

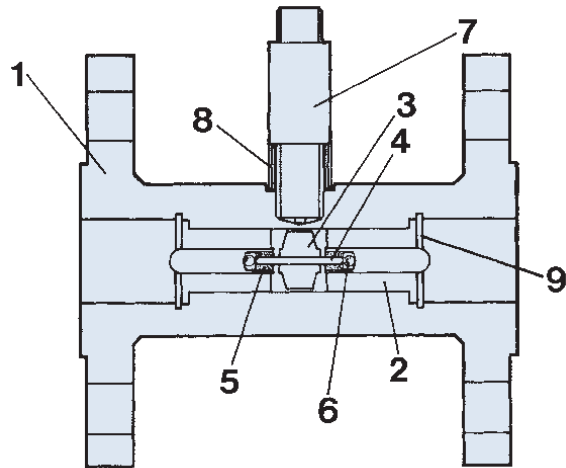

1	Housing	316 Stainless Steel
2	Bearing Hanger	316 Stainless Steel
3	Rotor	431 Stainless Steel
4	Spindle	Tungsten Carbide
5	Bearing Bushes	PTFE/Carbon filled or Tungsten Carbide
6	Thrust Ball	Tungsten Carbide
7	Pick off coil	Stainless Steel body
8	Collar	316 Stainless Steel
9	Circlip	302 Stainless Steel

Sizing table

Type Number	Flow Range (Linear)		Approx K-Factor		Linearity	Standard End Fittings		
	Ltrs/Min	I.G.P.M.	Ltr	Imp Gall		BSP Screwed	ANSI or BS10 E Flange	DIN Flange
NT3	0.5-5	.11-1.1	17000.0	771800.0	$\pm 0.5\%$	3/8"	1/2"	ND15
NT5	1.2-10	.22-2.2	5900.0	26780.0	$\pm 0.5\%$	1/2"	1/2"	ND15
NT7	2-20	.44-4.4	3000.0	13620.0	$\pm 0.5\%$	1/2"	1/2"	ND15
NT11	5-50	1.1-11	2600.0	11800.0	$\pm 0.5\%$	1/2"	1/2"	ND15
NT13	8-80	1.8-18	1950.0	8850.0	$\pm 0.5\%$	3/4"	1/2"	ND15
NT19	15-150	3.3-33	630.0	2860.0	$\pm 0.5\%$	1"	1"	ND25
NT24	25-250	5.5-55	350.0	1590.0	$\pm 0.5\%$	1"	1"	ND25
NT32	45-450	9.9-99	135.0	613.0	$\pm 0.5\%$	1 1/4"	1 1/2"	ND40
NT38	65-650	14.5-145	117.0	530.0	$\pm 0.5\%$	1 1/2"	1 1/2"	ND40
NT48	110-1100	25-250	67.0	305.0	$\pm 0.5\%$	2"	2"	ND50
NT65	200-2000	44-440	18.0	82.0	$\pm 0.5\%$	3"	2 1/2"	ND65
NT80	300-3000	66-660	14.0	64.0	$\pm 0.5\%$	-	3"	ND80
NT100	500-5000	110-1100	7.5	34.0	$\pm 0.3\%$	-	4"	ND100
NT150	1000-10000	220-2200	3.4	15.5	$\pm 0.3\%$	-	6"	ND150



Operations Principle

A ferritic stainless steel rotor revolves within a non-magnetic housing on the outside of which is located a pick off coil containing a permanent magnet. As the rotor blades pass the tip of the permanent magnet, the reluctance of the magnetic circuit is changed, and a small a.c. voltage is generated in the coil. The frequency of the a.c. voltage is proportional to flowrate, and the total number of pulses produced represents total flow passed through the meter.

The flowmeter may be located some considerable distance from the associated secondary instrument, and remote flowrate indication, total flow, and remote batch control are thus possible.

Installation and use

For best results the flowmeter should be installed well away from heavy current carrying cables and with control valves etc. located downstream of the meter.

A length of straight pipe of bore equal to the meter inlet should be provided, preferably 10 diameters in length, and if possible containing flow straightening vanes at the inlet end. Turbine meters are sensitive to swirl present upstream may cause a change in meter factor.

Strainers should be provided to minimise the risk of damage due to small solids in suspension. Meters may be installed in any attitude, but the flow direction and mounting attitude should be advised at the order stage if other than horizontal.

Varying densities have no appreciable effect on the accuracy of axial flow turbine meters so far as volumetric flow is concerned. If readout is required in mass flow terms, we can supply density or temperature compensation equipment to automatically correct for density variation. All turbine meters are to some extent sensitive to viscosity changes and any likely viscosity variation should be advised at the order stage.

Servicing may be carried out by our service engineers in the field, but meters should be returned to our factory wherever possible for repair. Bearing replacement can be effected on site by a skilled fitter, and instructions will be provided on request.

When requesting service visits or spares the full serial number should be stated, which immediately gives us access to the original order files for the installation.

Dimensions

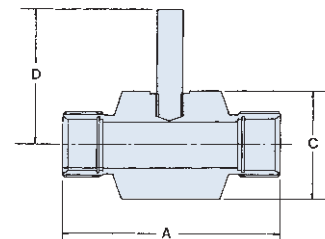
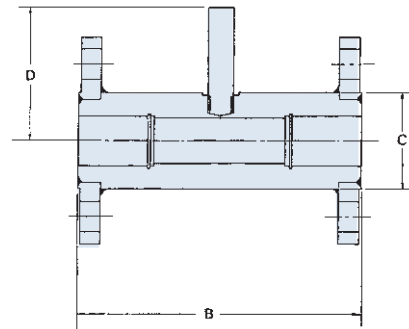

Allow an extra 50 mm height on dimension 'D' for pick off coil connector.

	A	B	C	D
NT3	51	110	25	82
NT5	64	110	25	82
NT7	64	110	25	82
NT11	85	110	38	84
NT13	85	110	38	86
NT19	114	150	51	89
NT24	114	150	51	91
NT32	135	174	64	95
NT38	150	174	64	98
NT48	180	210	76	103
NT65	-	258	100	112
NT80	-	316	100	119
NT100	-	386	167	130
NT150	-	410	167	155



Calibration method

Water is pumped from storage through the test meter, through a manual control valve into a collecting tank mounted upon a standard weighbridge, the vessel having a drain valve for return to storage.

At the commencement of a calibration, water is circulated through the system and allowed to drain whilst the operator regulates the control valve to set up the approximate desired flowrate. Next, a small weight, equal to about 10% of tank capacity is attached to the weighbridge arm, which when the arm is displaced is arranged by means of microswitches or an optical system, to switch on a high resolution pulse counter and a microsecond timer.

The drain valve is closed, and when the level reaches the preset value, the balance arm starts the counting procedure.

The operator now re-sets the balance arm, and attaches weights equal to the desired calibration volume whilst the collecting tank is filling.

When the second level is reached, the balance arm again deflects and closes the gating circuit of the counters.

Thus for one given flowrate, we can calculate pulses per unit of volume, and also the exact flowrate at which the calibration took place. This procedure is

then repeated at ten points over the operating range of the meter. Readings of pressure loss and output voltage are taken and the a.c. waveform is examined on an oscilloscope to detect any abnormalities in the rotor blades etc.

**NIXON FLOWMETERS LTD
CALIBRATION CERTIFICATE**

CUSTOMER		CERTIFICATE NO. 1614801 Feb-02	
MODEL NO	NS 50063	CALIBRATION MEDIUM	WATER
SERIAL NO	1614801	DENSITY (KG/M ³)	999.90
ENGINEER	C.P.	VISCOSITY (CPSE)	1
DATE	February 1, 2002	MAX FLOWRATE (L/MIN)	1.8
TEMPERATURE	14	SET VOLUME (LITRS)	1
TEST RIG	C		

We certify that the above meter was calibrated at our works using our normal gravimetric methods traceable to national standards. The meter was found to perform to a satisfactory manner. The following results were obtained:

TOTAL PULSES	TIME (SECS)	ACTUAL VOLUME	FLOW L/MIN	PULSES PER LITRE	% OF FLOW
25036	33.31		1.60	28518.04	133.1
25064	37.78		1.59	28544.02	88.3
25088	43.47		1.36	28546.12	76.7
28322	49.6		1.20	28302.19	96.6
26357	55.43	1.001	1.01	26357.16	96.1
26118	74.62	LTRS	0.80	26098.33	41.7
28168	89.81		0.60	28148.25	33.4
28362	114.75		0.41	28362.15	23.0
28430	330.88		0.18	28410.11	10.1
28510	33.4		1.80	28490.06	99.8

AVERAGE PULSES PER LTR	(K factor) 28376.84
RECIPROCAL OF PULSES PER LTR	3.528 05
FREQUENCY AT MAX FLOWRATE	855.48 HZ
LINEARITY OVER FULL RANGE %	0.782378
MINIMUM OUTPUT (MV)	80
MAXIMUM OUTPUT (MV)	703

SCHEMED WITH ESSEED
Bridgton Close, Leckhampton, Cheltenham, Glos ENGLAND Tel 01242 243006

A full 10 point calibration certificate is supplied with every flowmeter.

