

Insertion/Submersion Flow Through Sensor

- **ADVANCED ON-LINE SENSOR DIAGNOSTICS¹** (Model 381+ only), for use with the Models 54e pH/ORP and 1055 Analyzers and 81, 3081, 4081, 5081-P, and Xmt-P pH/ORP Transmitters, predict and identify process-related sensor failures.
- **MODULAR DESIGN** facilitates maintenance by eliminating terminal and mounting brackets and extraneous hardware.
- **DOUBLE-JUNCTION, GEL-FILLED REFERENCE CELL** provides high temperature performance, extended service life, and resistance to the effects of pumping, dilution, and contamination.
- **MOLDED POLYETHERSULFONE (PES) BODY** provides compatibility with a variety of processes.
- **OPTIONAL FLOW-POWERED CLEANING** provides trouble-free service in difficult applications.



FEATURES AND APPLICATIONS

The Rosemount Analytical Model 381 Sensor measures the pH or the Oxidation Reduction Potential (ORP) of aqueous solutions in pipelines, open tanks, or ponds. The sensor is suitable for use in most industrial applications, including water and waste treatment plants.

The Model 381+ features a stainless steel solution ground. The solution ground provides advanced sensor diagnostics for preventative maintenance when used with the Models 54e pH/ORP and 1055 analyzers and 81, 3081, 4081, 5081-P, and Xmt-P pH/ORP transmitters. Sensor diagnostics result in time and money savings by reducing the guesswork in sensor maintenance and replacement requirements.

The sensor is housed in a molded PES body and has two O-ring seals with breach lock threads that secure the PES cover. This provides a waterproof union for long operating life and easy removal for routine maintenance.

The modular body design eliminates the need for internal mounting brackets, terminal brackets, and screws. All components are screw-type or plug-in-place, allowing for fast simple service.

The integral preamplifier conditions the high impedance glass electrode signal at the sensor, providing a transmission capability of up to 1000 ft (304.8 m). The Rosemount Analytical method of preamplification has become the industry standard for reliable pH measurement. In submersion applications at temperatures greater than 80°C, the preamplifier must be located in a remote junction box or in the instrument.

A double-junction, gel-filled reference cell, a standard feature of the Model 381, improves sensor life when unknown reference cell contaminants, such as sulfides, may exist. The gel solution maintains its viscosity at high temperatures, and resists the effect of pumping and dilution, resulting in an extended

Continued on page 2

FEATURES AND APPLICATIONS

Continued from page 1

service life. A choice of a wood or ceramic liquid junction allows the user to optimize performance by emphasizing reference life (wood) or chemical resistance (ceramic).

In many flow applications, crystalline or viscous coatings are present, such as calcium carbonate or petroleum oils, which may coat the electrode surfaces and impede the sensor's performance. The flow-powered cleaning option may be used in these instances. A specially designed flow chamber directs the process

fluid in a circular path carrying three Teflon² balls that clean the electrode surface, physically preventing accumulation of coating materials. Flow-powered cleaning is suitable for all hazardous area applications.

The Model 381 is available with 3K Balco or Pt 100 temperature compensation and is compatible with all Rosemount Analytical pH/ORP Analyzers.

¹ Patent pending

² Teflon is a registered trademark of E.I. du Pont de Nemours & Company.

SPECIFICATIONS

Materials of Construction:

Body, Cover and Flow Cell: Polyethersulfone (PES)

O-Rings: Viton³

Measuring Electrode: Glass (and platinum or gold for Model 381 ORP)

Liquid Junction: Kynar⁴/wood (Code 20) or Kynar/ceramic (Code 21)

Solution Ground: 316 Stainless steel (Code + only)

Sensor Process Connections:

Submersion: 3/4 in. MNPT

Insertion: 2 in. MNPT

Flow Through Cell: 3/4 in. MNPT inlet and outlet

Measuring Ranges:

ORP; -1500 to +1500 mV

pH; ACCUGLASS⁵ 0-14

Minimum Conductivity: 75 $\mu\text{S}/\text{cm}$, nominal 100 $\mu\text{S}/\text{cm}$

Temperature Compensation: Automatic, 0 to 100°C (32 to 212°F)

Maximum Pressure/Temperature Rating: 790 kPa (abs) at 100°C (100 psig at 212°F)

Cable: For Code pH, pHE, ORP: 4 conductor, 22 GA with common shield. Code +: 10 conductor, shielded cable

Weight/Shipping Weight: 1.0 kg/1.7 kg (2.2 lb/3.7lb)

³ Viton is a registered trademark of E.I. du Pont de Nemours & Co.

⁴ Kynar is a trademark of Elf Atochem North America, Inc.

⁵ ACCUGLASS is a trademark of Rosemount Analytical.

Percent Linearity Over pH Range		
	General Purpose and Ruggedized glass (codes -10 & -12)	High pH glass (code -11)
0-2 pH	97%	94%
2-12 pH	99%	97%
12-13 pH	96%	98%
13-14 pH	92%	98%

* Note: Ruggedized glass electrodes are ideal for abrasive applications, but response times are typically slower than other glass formulas.

MOUNTING AND DIMENSIONAL DRAWING

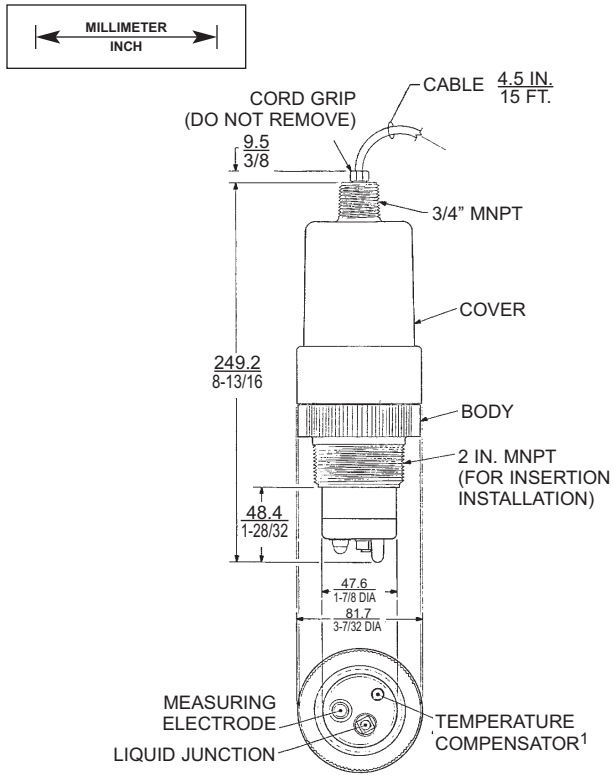

¹ ALSO SERVES AS SOLUTION GROUND FOR 381+

INSERTION AND FLOW THROUGH INSTALLATION

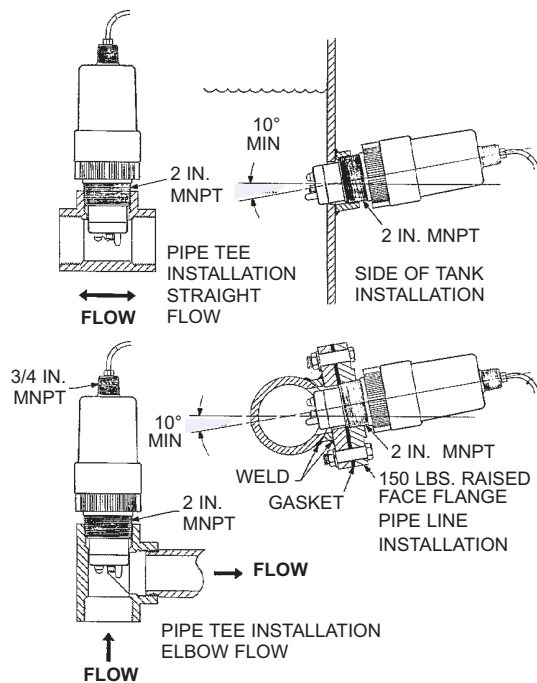

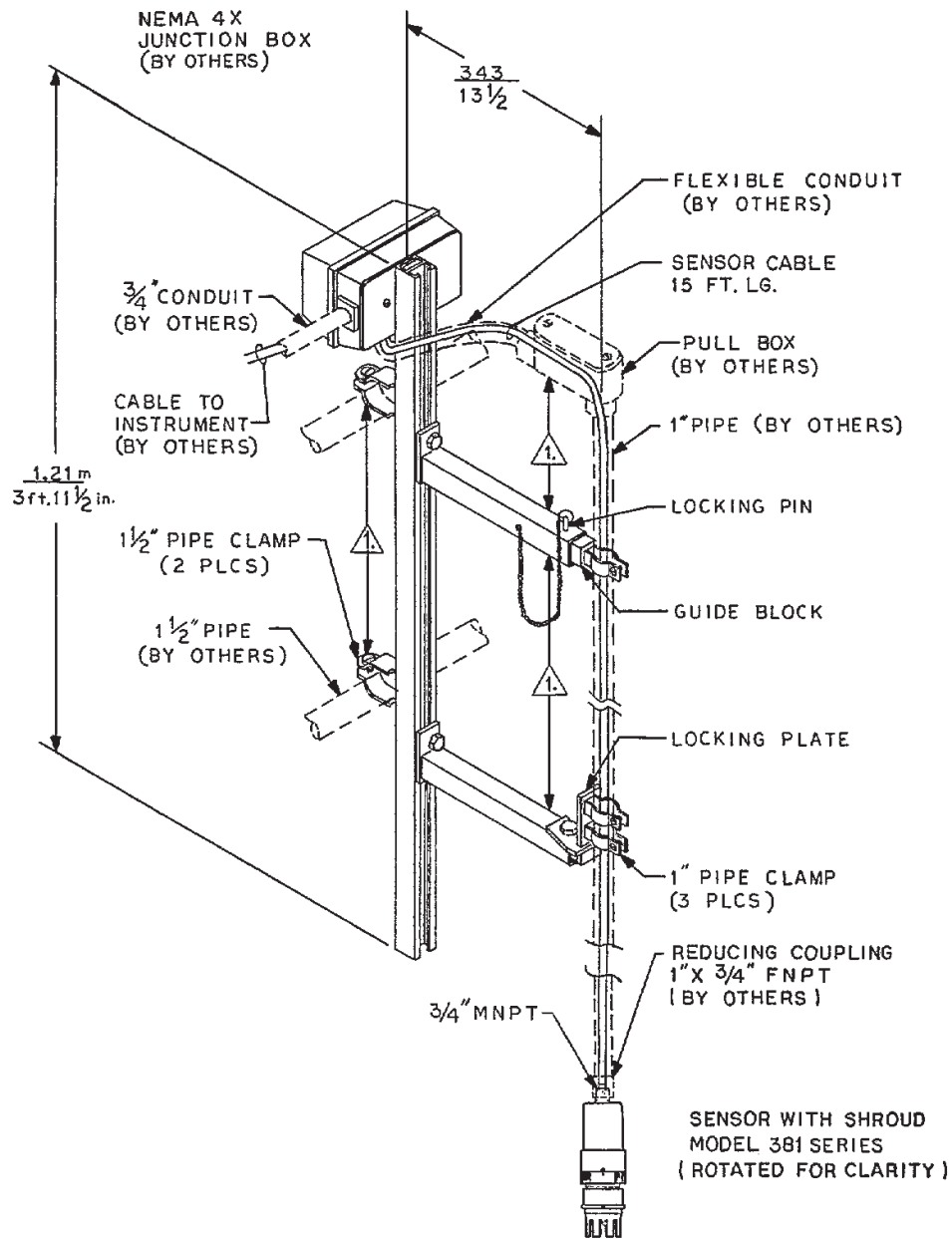

SUBMERSION INSTALLATION: HANDRAIL MOUNTING ACCESSORY (P/N 1000857)

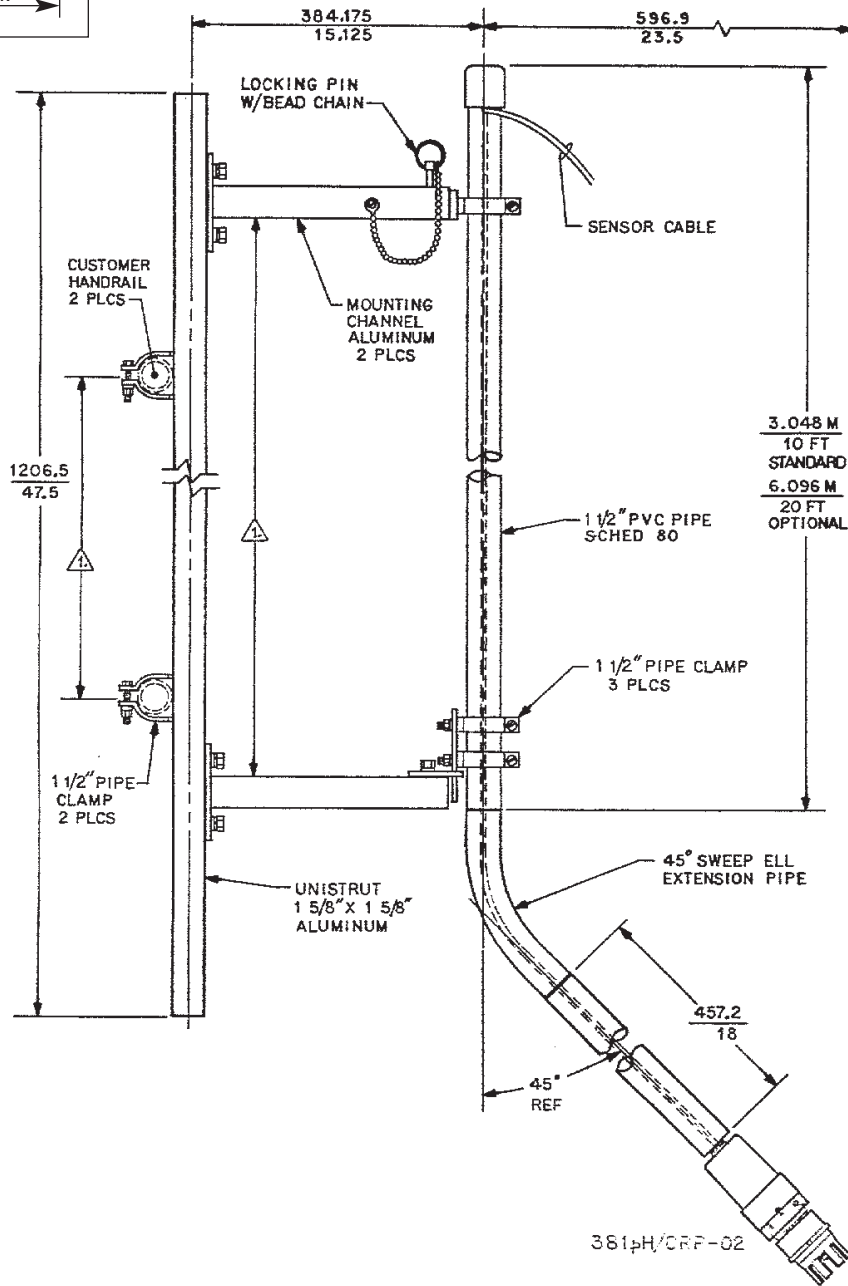

SUBMERSION INSTALLATION: HANDRAIL MOUNTING ACCESSORY (P/N 11275-00)



MODEL 381 SENSOR IN FLOW THROUGH ASSEMBLY

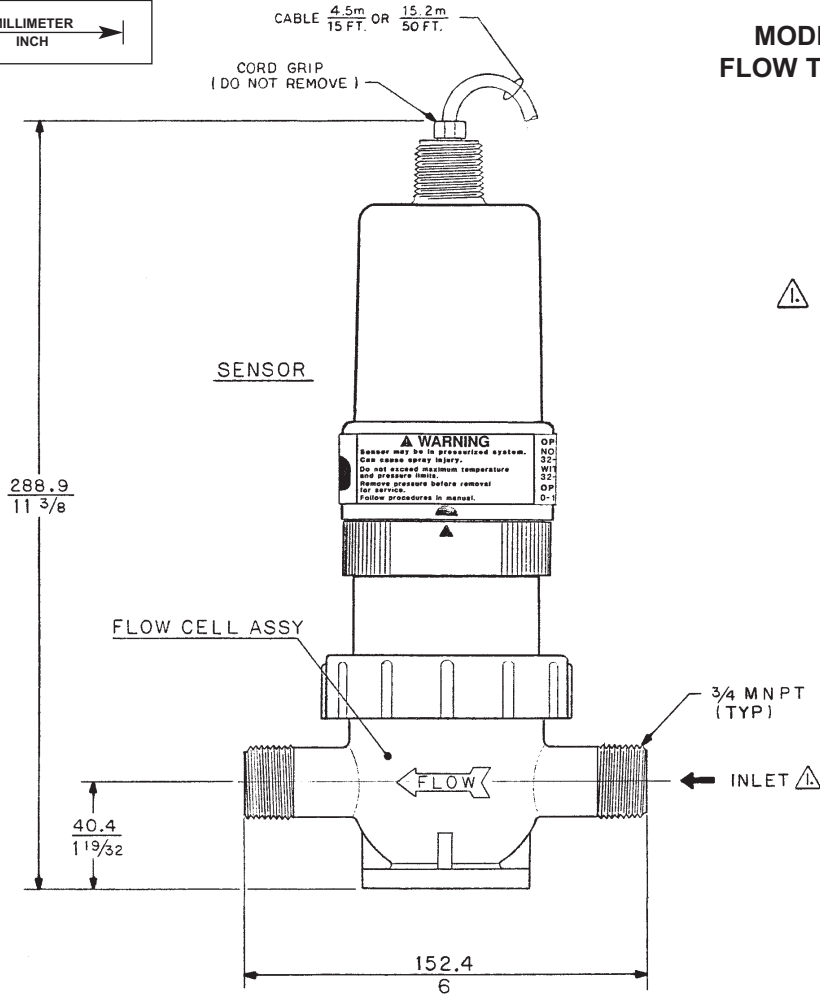

⚠ MODEL 381 SENSOR WITH FLOW POWERED CLEANER, MINIMUM FLOW RATE REQUIRED IS 2 gpm; DO NOT EXCEED 6 gpm AS THIS COULD CAUSE ELECTRODE DAMAGE.

381 FLOW POWERED CLEANER

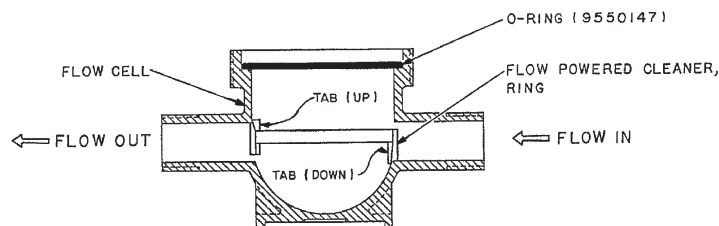
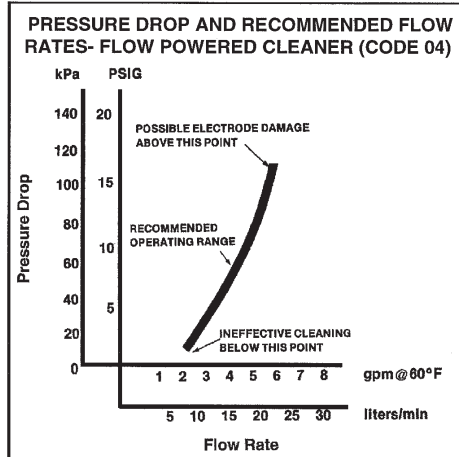
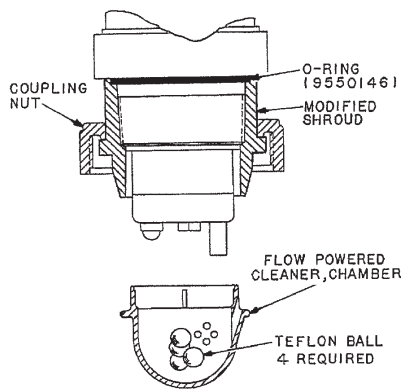

ORDERING INFORMATION

Model 381 pH/ORP Sensor is housed in a PES body suitable for insertion, submersion, or flow through installation. The sensor is offered with an integral preamplifier, measuring electrode, double-junction gel-filled reference cell, automatic temperature compensation for pH, and a choice of two cable lengths of either 15 ft or 50 ft (4.5 or 15.2 m).

MODEL 381		INSERTION, SUBMERSION, FLOW THROUGH SENSOR						
CODE	FUNCTION							
pH	pH assembly for Models 1003, 1023, 1050, 1060, and 1181pH; requires Code 30							
PE	pH or ORP assembly for Models 1054, 1054A, 1054B, 2054, and 2081; requires Code 31							
+	pH or ORP assembly for Models 54/54e, 1055, 81, 3081, 4081, 5081-P, Xmt-P; requires Code 31							
OR	ORP assembly for Models 1003, 1023, 1050, 1060, and 1181ORP; requires Code 32							
CODE	INSTALLATION							
02	Submersion, 3/4 in. MNPT							
03	Flow Through Assembly, 3/4 in. MNPT inlet and outlet							
04	Flow Through Assembly with Flow Powered Cleaner (not available with ORP), 3/4 in. MNPT inlet and outlet							
CODE	MEASURING ELECTRODE							
10	General purpose pH, GPHT (0-14), not available with Code OR							
11	High pH Electrode, requires Code 21. For sodium concentrations greater than 1 or continuous measurement above 11 pH; not available with Code OR							
12	Ruggedized pH Electrode. For abrasive solutions, not available with Code OR							
13	Platinum ORP Electrode, not available with Code pH							
14	Gold ORP Electrode, not available with Code pH							
15	HF pH Electrode. For HF concentrations less than 300 ppm, not available with Code OR							
CODE	LIQUID JUNCTION							
20	Wood/Kynar Liquid Junction							
21	Ceramic/Kynar Liquid Junction							
CODE	TEMPERATURE COMPENSATION							
30	Automatic TC, 3K ohm. For Models 1003, 1023, 1050, 1060, & 1181pH							
31	Automatic TC Pt 100, 100 ohm RTD. For Models 1054 series, 2054, 2081, 54/e, 81, 3081, 4081, 5081-P, Xmt-P							
32	Automatic TC NOT REQUIRED. For Models 1003, 1023, 1050, 1060, & 1181 OR							
CODE	CABLE							
40	15 ft (4.5 m) cable for integral sensor preamp (see below for preamp choices)							
41	15 ft (4.5 m) coax cable w/BNC connector for remote sensor preamp and integral analyzer preamp (Models 1054A-54, 1054B-54, 2054-54 and 54e, 1055, 81, 3081, 4081, 5081-P, and Xmt-P)							
42	15 ft (4.5 m) coax cable w/o BNC connector for integral analyzer preamp (Models 1054, 1181-43/44, and 2081-05 only), not available with Codes OR and +							
43	50 ft (15.2 m) cable for integral sensor preamp (see below for preamp choices)							
CODE	INTEGRAL PREAMPLIFIER							
50	Preamp for Models 1181 pH/ORP & 1050/1060							
51	Preamp for Models 1003/1023							
52	Preamp NOT REQUIRED (uses Code 41 or 42 only)							
54	Preamp for Models 1054, 1054A, 1054B, 2054, and 2081							
55	Preamp for Models 54/e, 81, 3081, 4081, 5081-P, and Xmt-P (for Code+ only)							
381	pH	00	10	20	30	40	50	EXAMPLE

NOTE: Model 2700 Analyzer can be used only with Models 381+-31/33-45-52.

MODEL 381 pH, PE, OR ACCESSORIES

PART #	DESCRIPTION
1000857	Handrail mounting bracket for submersion service, for use with remote junction box
22697-00	Combination pH electrode, general purpose
22697-01	Combination pH electrode, high pH
22698-00	Preamplifier for use with Models 1003, 1023
22698-02	Preamplifier for use with Models 1050, 1181
22698-03	Preamplifier for use with Models 1054/2054 Series, 2081
22719-02	Remote junction box
22811-00	Flow cell (includes electrode shroud)
22892-00	Flow powered cleaner retrofit kit (for use with Option -03 sensors)
22996-00	Remote junction box for internal preamp
23296-00	Remote Division 2 junction box for internal preamp for use with Models 1181pH/ORP, 1050/1060, 1003/1023
23296-01	Remote Division 2 junction box for internal preamp for use with Models 1054/2054 Series, 2081
9200160	Extension cable, sensor or remote preamp to analyzer, specify length

MODEL 381+ ACCESSORIES

PART #	DESCRIPTION
11275-00	Handrail mounting bracket for submersion service
1000857	Handrail mounting bracket for submersion service, for use with remote junction box
22892-00	Flow powered cleaner retrofit kit (for use with option -03 sensors)
23550-00	Junction Box, with extension board 54, 81, 3081, and 4081 compatible
23646-01	Extension cable, double shield, prepped, specify length, for option -40 and -43
23555-00	Remote junction box with preamp for 54/e, 81, 3081, 4081, 5081-P, and Xmt-P compatible, for option -40 and -43
23557-00	Preamplifier for junction box, 54/e, 81, 3081, 4081, 5081-P, and Xmt-P compatible
9200273	Extension cable, 10 conductor, shielded, unprepped, specify length



*The right people,
the right answers,
right now.*

ROSEMOUNT ANALYTICAL
CUSTOMER SUPPORT CENTER
1-800-854-8257

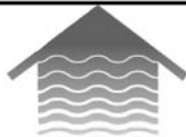

ON-LINE ORDERING NOW AVAILABLE ON OUR WEB SITE
<http://www.raihome.com>

Specifications subject to change without notice.



Credit Cards for U.S. Purchases Only.



Emerson Process Management

Liquid Division

2400 Barranca Parkway
Irvine, CA 92606 USA
Tel: (949) 757-8500
Fax: (949) 474-7250

<http://www.raihome.com>